



Endicott Research Group, Inc.

2601 Wayne St., Endicott, NY 13760

607-754-9187 Fax 607-754-9255

http://www.ergpower.com

SFDMB3718F



Specifications and Applications Information

11/06/08

Preliminary

Smart Force LED Driver

The ERG **Smart Force Series** of LED Drivers are specifically designed for applications which require high efficiency, small footprint and LCD brightness stability over a wide input voltage range. The SFDMB3718F is designed to provide backlighting for the AU Optronics G065VN01 V.0 backlight.

Designed, manufactured and supported within the USA, the SFDM features:

- ✓ Less than 5 mm in height
- ✓ Wide input voltage range
- ✓ Constant LED current
- ✓ With external PWM dimming signal, up to 1000:1 dimming ratio
- ✓ Open and short circuit protection
- ✓ High efficiency
- ✓ Separate enable and dimming function
- ✓ Soft start
- ✓ One year warranty

Package Configuration

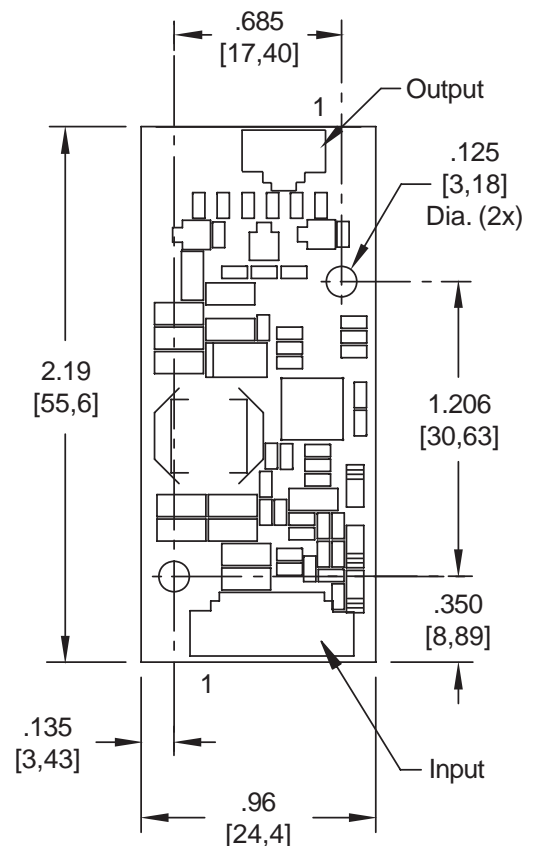

PCB components are shown for reference only. Actual product may differ from that shown.

Mass: 7 grams typ.



Connectors

Input Connector	Output Connector
Molex 53261-0871	Molex 53261-0471
J1-1 Vin(+) J1-2 Vin(+) J1-3 GND J1-4 GND J1-5 Enable J1-6 PWM J1-7 N/C J1-8 Fault Indicator (output)	J2-1 Cathode 1 J2-2 Anode 1 J2-3 Cathode 2 J2-4 N/C

**Absolute Maximum Ratings**

Rating	Symbol	Value	Units
Input Voltage Range	V_{in}	-0.3 to +20.0	Vdc
Storage Temperature	T_{stg}	-40 to +85	°C
Enable Input Voltage	V_{Enable}	0 to V_{in}	Vdc
PWM Input Voltage	V_{PWM}	0 to +5.0	Vdc
Fault Indicator	V_{FL}	0 to +4.0	Vdc

Operating Characteristics

Unless otherwise noted $V_{in} = 12.00$ Volts dc and $T_a = 25^\circ\text{C}$.

Characteristic	Symbol	Min	Typ	Max	Units
Input Voltage	V_{in}	+8.0	+12.0	+16.0	Vdc
Component Surface Temperature (Note 1)	T_s	-40	-	+80	°C
Input Current	I_{in}	0.31	0.37	0.43	Adc
LED String Voltage (Note 2)	V_{LED}	20.0 (Note 3)	-	38.5	Vdc
Efficiency (Note 4)	h	-	90	-	%
Output Current (per string)	I_{out}	73.2	77.0	80.9	mAdc
Enable Pin (Note 5)					
Turn-on Threshold	V_{thon}	-	-	3.5	Vdc
Turn-off Threshold	V_{thoff}	0.8	-	-	Vdc
Enable Input Impedance (Note 6)	R_{Enable}	-	9.0	-	kOhms
PWM Pin (Note 7)					
Turn-on Threshold	V_{thon}	-	-	2.0	Vdc
Turn-off Threshold	V_{thoff}	0.9	-	-	Vdc
PWM Input Impedance (Note 8)	R_{PWM}	-	9.0	-	kOhms
Frequency (Notes 9, 10)	F_{PWM}	130	-	40,000	Hz

(Operating Characteristics and notes are continued on next page.)

**Operating Characteristics** (continued)

Characteristic	Symbol	Min	Typ	Max	Units
Fault Indicator					
No Fault Level (Note 11)	V_{NFL}	-	2.5	-	Vdc
Fault Level (Note 11)	V_{FL}	-	0.3	-	Vdc

Specifications subject to change without notice.

- Note 1 Surface temperature must not exceed 80°C, except U1, which cannot exceed 95°C.
Note 2 Exceeding maximum string voltage specification will damage the LED driver.
Note 3 The LED driver is capable of driving strings less than the minimum string voltage specification, although doing so will limit the maximum input voltage.

To determine max V_{in} :

$$\text{minimum LED string voltage} \geq (1.3) \times (V_{in \text{ maximum}})$$

- Note 4 Efficiency is calculated using a 26V LED string.
Note 5 The Enable pin is internally pulled up above the turn-on threshold.
Note 6 Enable pin input impedance is 9kΩ to 10V with a 12V input voltage.
Note 7 PWM pin is internally pulled up above the turn-on threshold.
Note 8 PWM pin input impedance is 9kΩ to 4V with a 12V input voltage.
Note 9 Operating outside of this frequency range may cause the driver to shut down or malfunction.
Note 10 Minimum pulse width required for reliable operation is 5μs.
Note 11 Loading with an impedance less than 100kΩ to Vcc or to ground may cause the default levels to change.



Application Information

The ERG SFDMB3718F has been designed to be configured in multiple ways:

NO DIMMING

- OPERATION: The SFD can be configured to operate without dimming by floating the Enable (J1-5) and PWM (J1-6) pins.
- Pins 1 and 2 of connector J1 must be connected to +Vin, between 8 and 16 Vdc. Pins 3 and 4 of connector J1 must be connected to GND.
- DISABLING DRIVER: Pulling the Enable pin (J1-5) below the minimum turn-off threshold of 0.8V will disable the driver. Disabling the driver will require the ability to sink $\geq 2\text{mA}$ below the turn-off threshold. This pin may be driven by an open collector stage or a totem pole stage.

EXTERNAL PWM DIMMING

- OPERATION: External PWM configuration as shown in Figure 1 allows the user to control display brightness with an externally generated PWM signal. The user is responsible to provide the PWM signal. A dimming ratio up to 1000:1 is possible with this configuration. The minimum pulse width is 5 μs .
- DIMMING: Dimming is accomplished by applying a PWM signal to the PWM pin (J1-6). PWM on and off levels are specified in the Operating Characteristics section of the data sheet. Display brightness is modulated by controlling the PWM duty cycle as shown in Graph 1. Pin 6 may be driven by an open collector stage capable of sinking $>1\text{mA}$, or a totem pole stage.
- Pins 1 and 2 of connector J1 must be connected to +Vin, between 8 and 16 Vdc. Pins 3 and 4 of connector J1 must be connected to GND. Pin 5 must either be floating or above the full on threshold if being driven by a totem pole stage.
- DISABLING DRIVER: Pulling the Enable pin (J1-5) below the minimum turn-off threshold of 0.8V will disable the driver. Disabling the driver will require the ability to sink $\geq 2\text{mA}$ below the turn-off threshold. This pin may be driven by an open collector stage or a totem pole stage.

FAULT INDICATOR

- The Fault Indicator pin (J1-8) may be used as a feedback signal that will fall below the fault level of 0.3V in the case of an open string, a shorted string, an output overvoltage condition, or an over temperature condition. If used, this pin should be loaded with a high impedance stage as specified in the Operating Characteristics. Do not drive this pin with a voltage, as it will damage the driver.



EXTERNAL PWM DIMMING

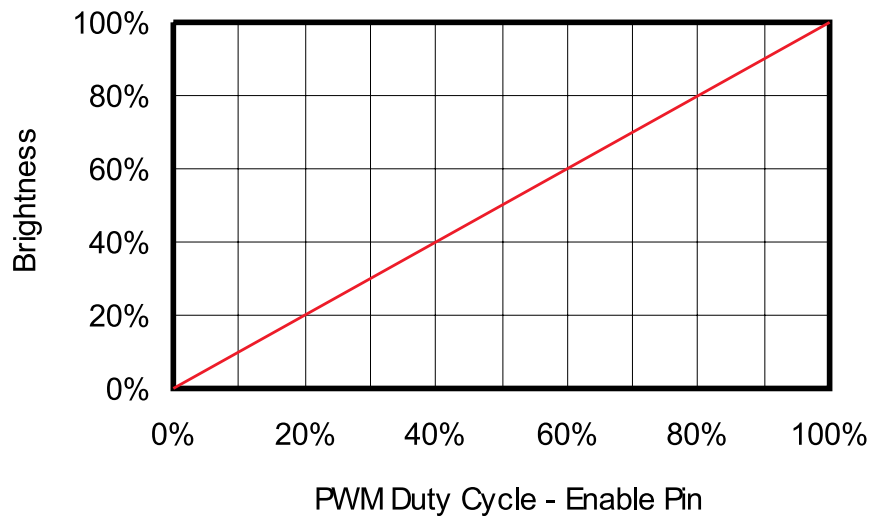

Graph 1

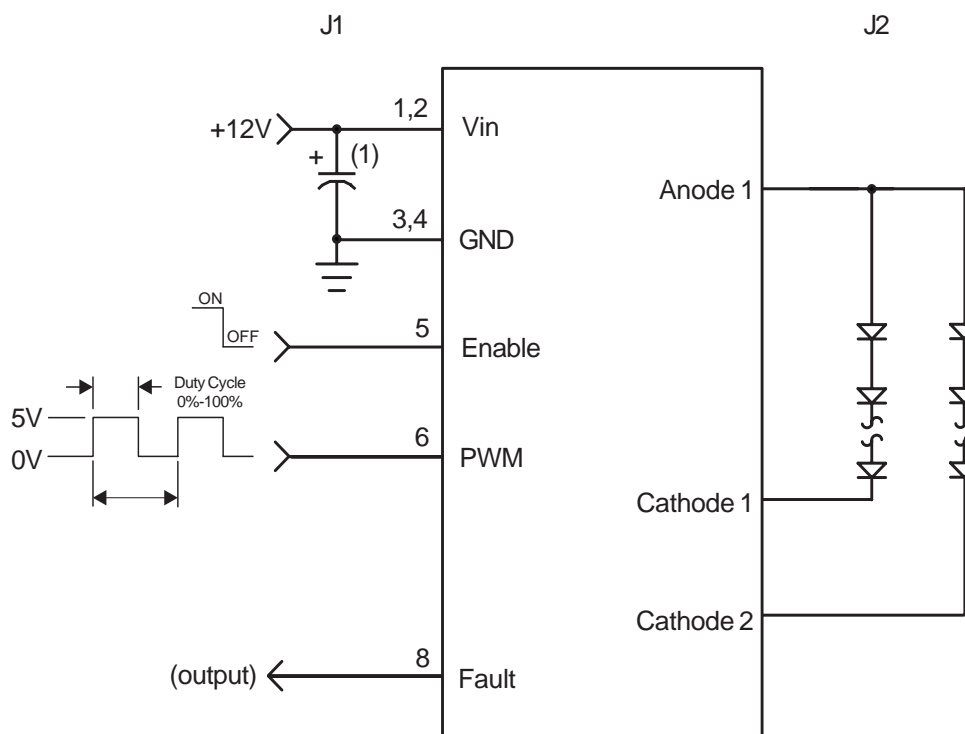

Figure 1

- (1) Low ESR type input by-pass capacitor (10 uF - 220 uF) may be required to reduce reflected ripple and to improve power supply response.



Endicott Research Group, Inc. (ERG) reserves the right to make changes in circuit design and/or specifications at any time without notice. Accordingly, the reader is cautioned to verify that data sheets are current before placing orders. Information furnished by ERG is believed to be accurate and reliable. However, no responsibility is assumed by ERG for its use.